

PHOTO BEAM

R4222

THROUGH BEAM

PHOTOELECTRIC DUAL BEAM DETECTOR

Manual
R4222



PARTS

COVER

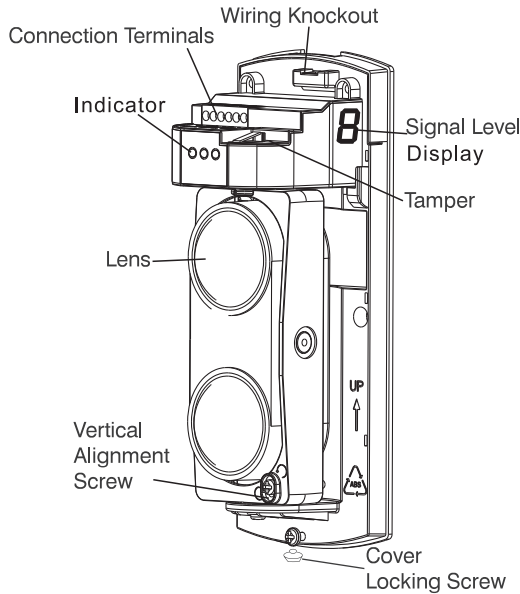
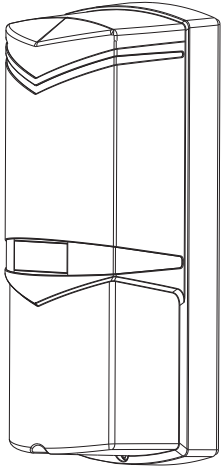

INTERNAL VIEW OF RECEIVER

RECEIVER INDICATORS

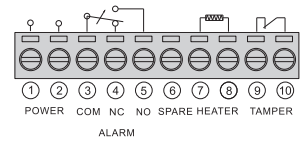

- **GOOD LED (green).** Use when adjusting beam alignment. ON when beams are aligned, OFF when beams are not aligned. (Refer to operation instructions)
- **LEVEL LED (red).** ON indicates received signal. Brightness varies, depending on incident level.
- **ALARM LED (red).** ON indicates beam blocked. Use when setting response time. (Refer to operation instructions)

TRANSMITTER INDICATOR

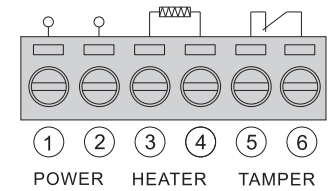

- **POWER LED (green).** ON when light beam is transmitting.



MOUNTING CAUTIONS *Do not mount the detector in the following conditions:*



Where obstructions (plants, fences, etc.) are between the receiver and the sender.



Where the mounting surface is unstable.

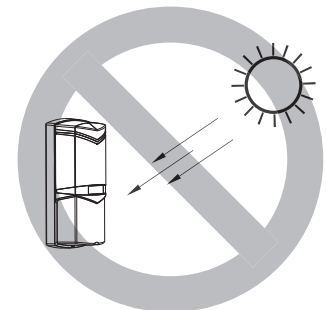

Where sunlight and headlights shine directly into the front of the receiver.

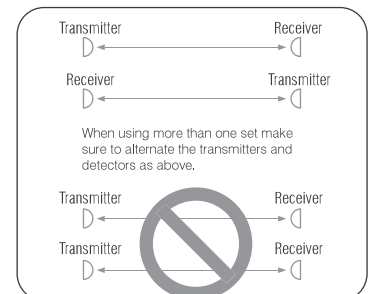
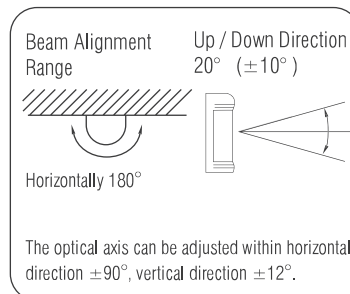
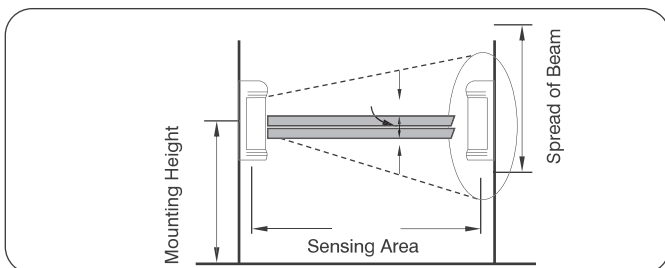



MOUNTING AND CONNECTIONS

1. Loosen the cover-holding screw and remove the outer cover.

2. Remove the rubber knock-out and use the screw holes to mount the unit.

3. Remove the rubber knock-out and pull the wire through.

4. Mount the detector on the wall.

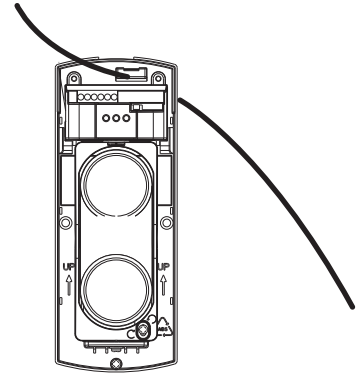
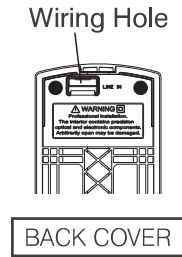
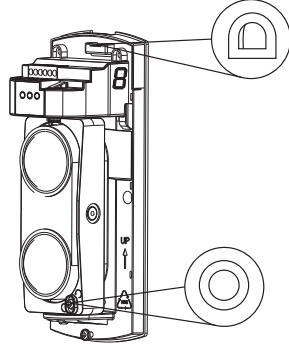
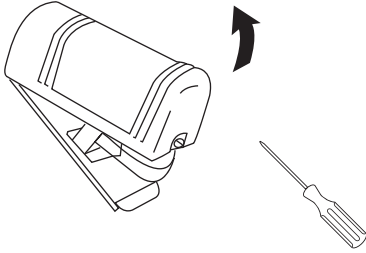

5. Connecting wires to the terminals

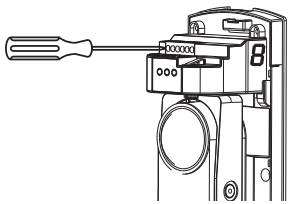

Transmitter Terminal Wiring Pattern

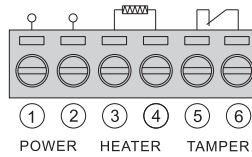

Receiver Terminal Wiring Pattern

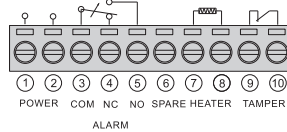

- Wire with 22awg minimum
- 300 ft (91.4m) max length
- Be sure to capture the wire ends under the wire clamp plates.
- Avoid frayed ends on wires that might produce a short circuit.

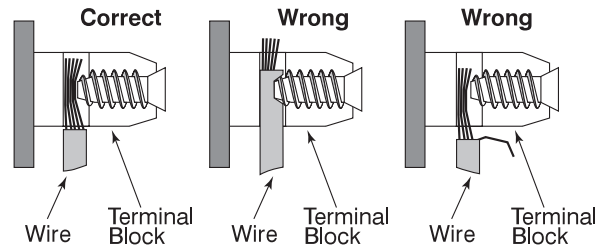

Pole Mounting

1. Break out the wire hole on the bracket then pull out the wires.

2. Remove the cover. 3. Fix the base plate on the bracket.

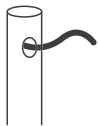

diameter of the bracket

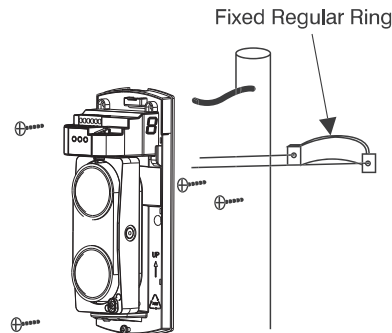

4

DIP SETTING

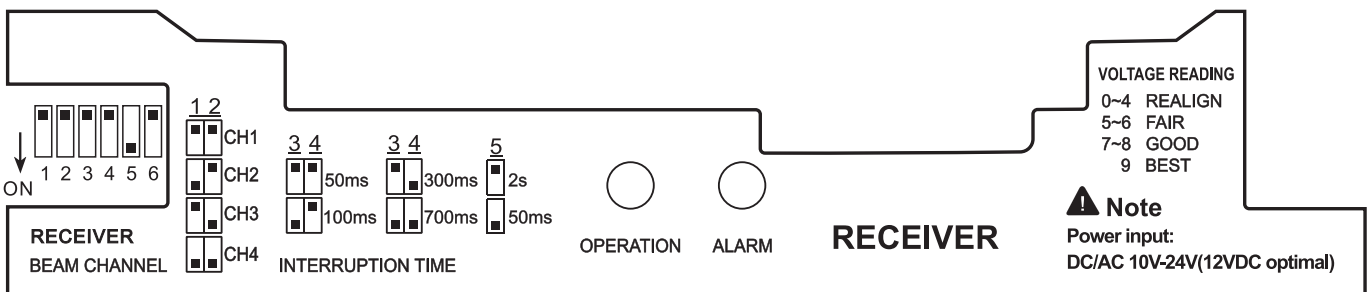
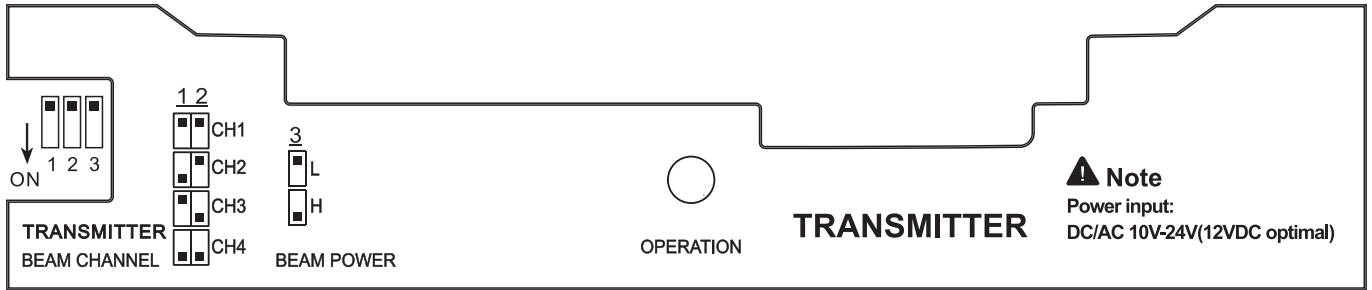

Note

1. DIP 1 & 2 on Transmitter & Receiver must be on the same position(Same channel)
2. Dial the PIN 5 at "ON" position on Receiver, STARTUP time is about 0.06S.

5

BEAM ALIGNMENT

1. Remove the cover and turn ON power.

2. Adjust the horizontal pivot, and the vertical adjustment screw using the built-in viewer. Look through the peep hole on either side and adjust to put the opposite sensor in the middle of the cross-hairs in the viewfinder.

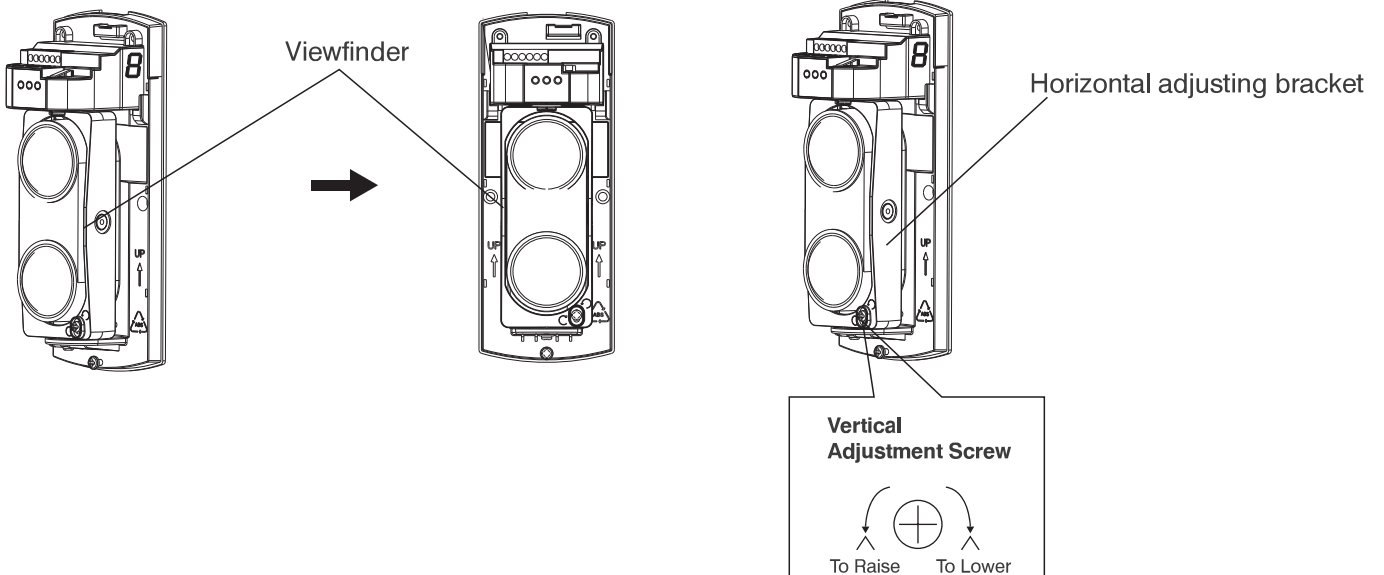

6

BEAM INTERRUPTION TIME ADJUSTMENT

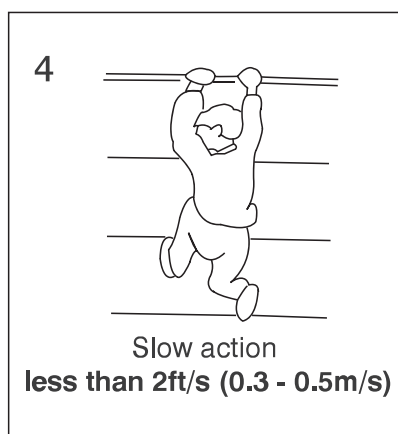
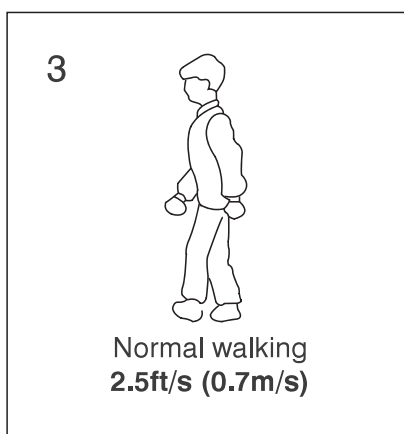
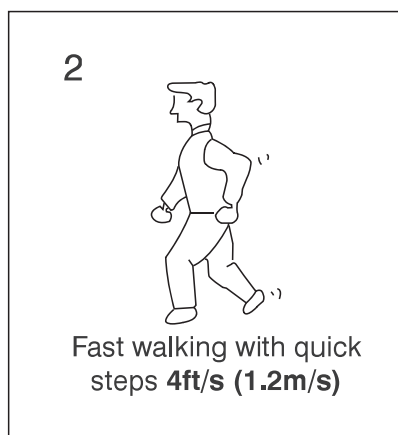
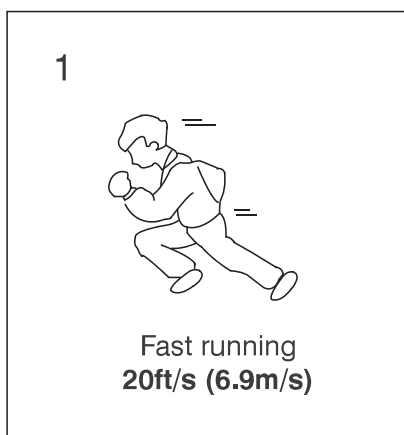

7

VERIFY CORRECT OPERATION

After installation, confirm correct operation by suitable walking tests.

Refer to the appropriate LED indicator during the walking test.

	Condition	Indication
Transmitter	Transmitting	Green LED is ON
Receiver	Beam Clear	GOOD-LEVEL Indication
	Beam Blocked	Alarm indication lamp is ON



TROUBLESHOOTING

Symptom	Possible Cause	Remedy
Transmitter LED does not light.	Improper voltage supplied.	Check the power supply and wiring.
Receiver LED does not light.	Improper voltage supplied.	Check the power supply and wiring.
Alarm LED does not light, even when beams are blocked.	<ol style="list-style-type: none"> 1. Beams reflect to the receiver by other objects. 2. Both beams are not blocked simultaneously. 3. Beam block time is too short. 	<ol style="list-style-type: none"> 1. Remove the reflecting object or change optical axis direction. 2. Block both beams. 3. Increase beam block time.
When the beams are blocked, the receiver LED light is ON, but not alarm.	<ol style="list-style-type: none"> 1. Wiring is short circuited. 2. Wiring connection is not good. 	Check wiring and connection spot.
The alarm indication lamp of receiver is always on.	<ol style="list-style-type: none"> 1. Optical axis is not properly adjusted. 2. There are obstructions between the transmitter and the receiver. 3. The outer covers are dirty. 	<ol style="list-style-type: none"> 1. Adjust the optical axis. 2. Remove the obstructions. 3. Clean with window cleaner and a soft cloth.
Intermittent Alarm	<ol style="list-style-type: none"> 1. Bad wiring. 2. Fluctuating power supply / voltage. 3. Intermittent blockage between the transmitter and the receiver. 4. The receiver or transmitter is unstable. 5. Blocked by other moving objects. 	<ol style="list-style-type: none"> 1. Check wiring. 2. Check the power supply. 3. Remove the obstruction or relocate. 4. Fix the mounting. 5. Adjust the optical axis. 6. Adjust interruption time or change installation position.



SPECIFICATIONS

Model	R4222	
Detection Method	Infrared photoelectric	
Range	Outdoor	98.4 ft (30m)
	Indoor	295.2 ft (90m)
Beam Characteristics	Pulsed infrared dual beams	
Response Time	50~700msec (selectable)	
Power Input	DC12V~24V	
Current Consumption	40mA max	
Output Pulse Duration	2Sec (±1)nominal	
Alarm Output	Form C relay (AC/DC 30V 0.5A max)	
Tamper Switch	N.C. Opens when cover is removed (receiver only)	
Operating Temperature	-13°F (-25°C)~131°F (55°C)	
Environment Humidity	95% max	
Alignment Angle	±5° vertical, ±90° horizontal	
Mounting	Wall or pole	
Weight	.66lbs (300g) Both transmitter and receiver	
Appearance	PC Resin (Black)	